

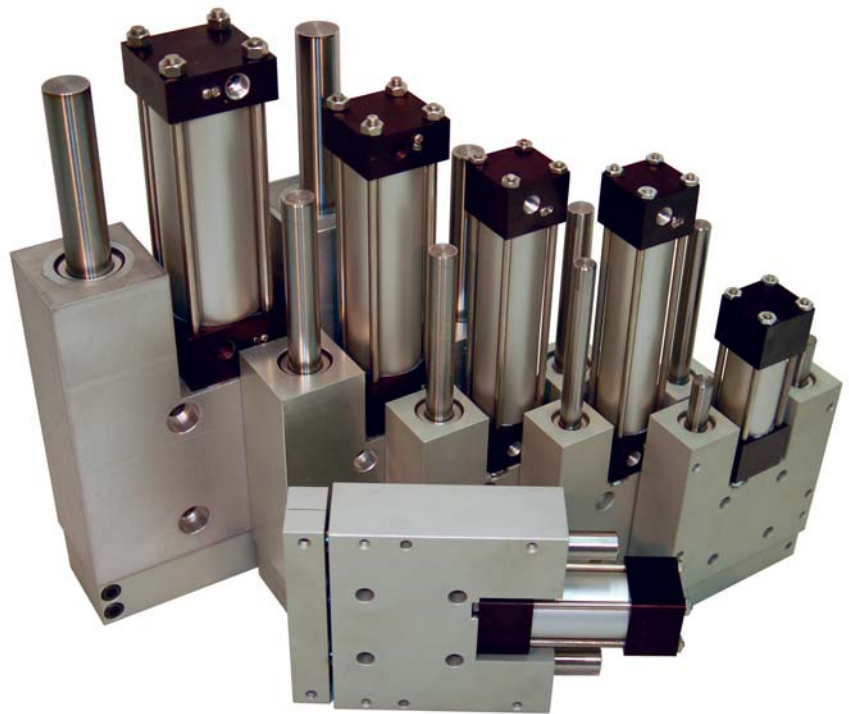

ITT

# Z-Series Cylinders



*Engineered for life*

# Z-Series Cylinders: Table of Contents

## Z-Series

Slide Features .....pg. 2

**ZD and ZE Series**.....pg. 3

Quick Reference.....pg. 3

## How to Order:

Z Series .....pg. 4

## Options:

Z Series .....pg. 5

## Dimensional Data

ZD Series.....pg. 6

ZE Series .....pg. 7

## Engineering Data

ZD and ZE Series Series .....pgs. 8-15

**Warranty** .....pg. 16

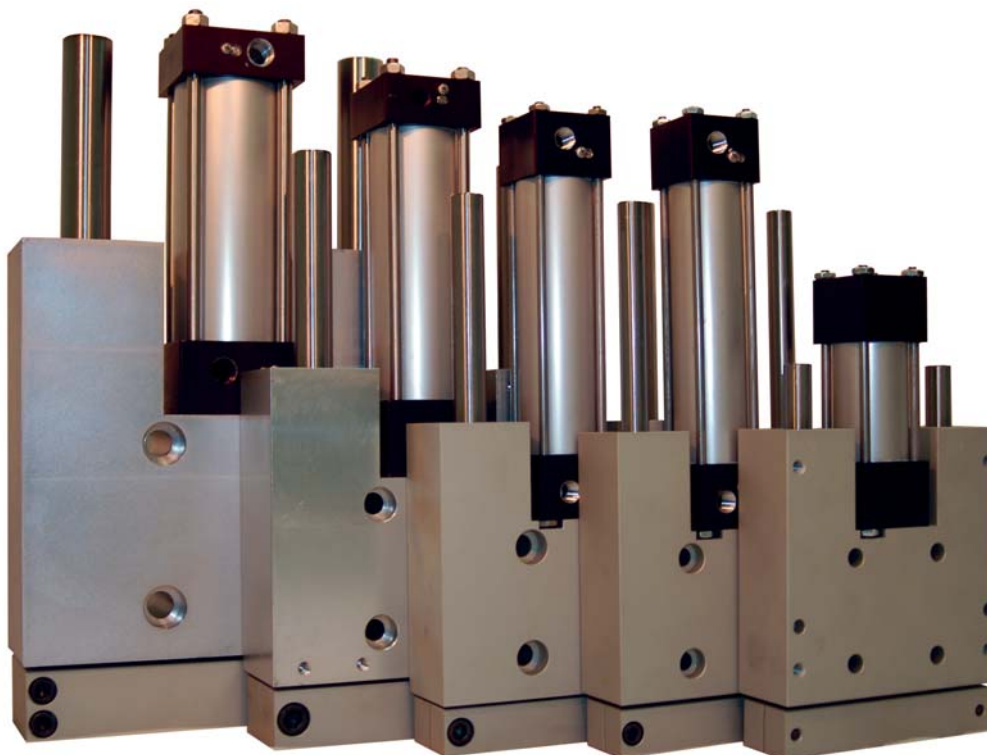

# Z Series Slide Features

## ZD Series Slide

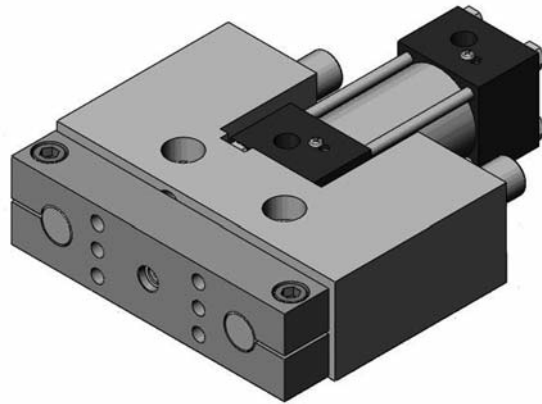

### CYLINDER STYLE

- Tie Rod Cylinder

### GUIDE ROD MATERIALS

- Standard Hardened Carbon Steel
- Hardened Stainless Steel
- Ceramic Coated Light Weight Aluminum
- Corrosion Resistant Coated Hardened

### GUIDE ROD/BUSHING DIAMETERS

- Standard – solid performance with linear ball or composite bushings
- Oversize – greatest rigidity with minimal deflection

### TOOLING PLATE

- Pinch type tooling plate connection improves rigidity providing a sturdy system ideal for precise movement and accurate location

## ZE Series Slide

### GUIDE BUSHINGS

Composite or Linear ball

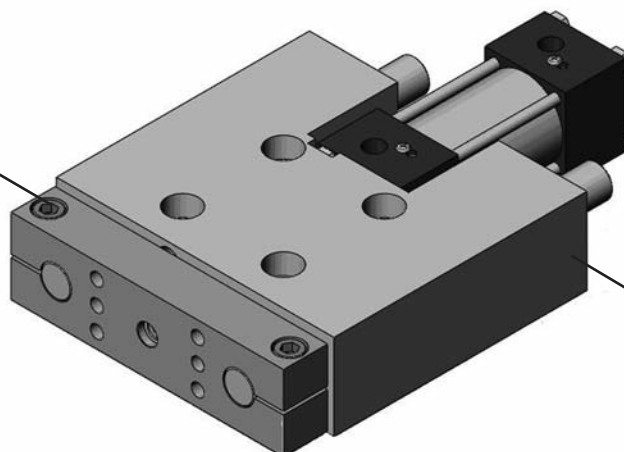

### ZE Series (Long Body)

Offers greater distance between the bearings, longer travel and higher load

# ZD and ZE Series

## GUIDED SLIDES:

- **Cylinders - Tie Rod Cylinder**
  - Available Bores 1-1/8", 1-1/4", 1-1/2" and 2".
- **Slide Bodies - Anodized machined aluminum**
  - ZD (Short Body) perfect for tight space and shorter travel where size and weight are critical.
  - ZE (Long Body) the longer body spreads the distance between the guide bushings, contributes to rod rigidity, best for longer strokes and higher load applications.
- **Guide Bushings Types - (2 per Guide Rod)**
  - Linear Ball with shaft seals, high precision.
  - Composite (fluoropolymer) Internally lubricated, high performance and cost effective.
- **Guide Rod Types**
  - Hard precision ground shafts provide smooth tooling plate motion under load.
  - Oversize shafting utilized with composite bearing for greater rigidity with minimum rod deflection.
- **Guide Rod Materials (Precision Ground - Class L)**
  - Standard hardened steel.
  - Hardened stainless steel.
  - Corrosion resistant coated hardened steel
  - Aluminum ceramic coated light weight

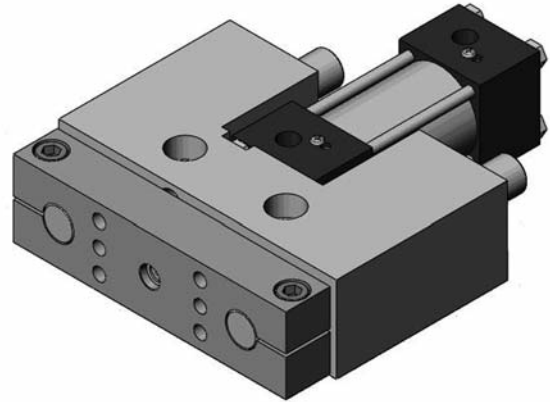

- **Tooling Plates**
  - Machined mounting face
  - Combination tapped and counterbored mounting holes
  - Close fit dowel pin holes
  - Pinch type tooling plate connection
- **Options**
  - Shock pads
  - Stop collars
  - Shock absorber mounting
  - Proximity switch ready
  - Reed & solid state switches available
  - Normal fit dowel pin holes available

## Quick Reference

Piston Area (in <sup>2</sup> )				
Size	Bore	Extend	Retract	Pist. Rod Diam.
23	1-1/8"	1.00	.80	5/16"
24	1-1/4"	1.23	1.12	3/8"
25	1-1/2"	1.77	1.62	5/8"
26	2"	3.14	2.95	5/8"

Port Size	
Slide Size	Standard Port Size
23	1/8 NPT
24	1/8 NPT
25	3/8 NPT
26	3/8 NPT

BEARING TYPE	GUIDE ROD DIAMETERS	CYLINDER BORE
Linear Ball	1/2"	1-1/8"
Std Composite	1/2"	
Oversize Composite	5/8"	
Linear Ball	5/8"	1-1/4"
Std Composite	5/8"	
Oversize Composite	3/4"	
Linear Ball	3/4"	1-1/2"
Std Composite	3/4"	
Oversize Composite	1"	
Linear Ball	1"	2"
Std Composite	1"	
Oversize Composite	1-3/8"	

# How to Order: Z Series Slides

SERIES	BODY STYLE	BUSHING TYPE	SIZE	SLIDE TRAVEL	TOOLING PLATE GAP	OPTIONS	OPTIONS
Z	D	B	24	2.25	2	Q	AR
1	2	3	4	5	6	7	7

**1 Series**

<b>Z</b>	Slide
----------	-------

**2 Body Style**

<b>D</b>	Short Body
<b>E</b>	Long Body

**3 Bushing Type**

<b>B</b>	Linear Ball Bushings
<b>C</b>	Standard Composite Bushings
<b>D</b>	Oversize Composite Bushings

**4 Size**

Size	Guide Rod Diameter		
	Standard	Oversize	Bore
<b>23</b>	1/2"	5/8"	1-1/8"
<b>24</b>	5/8"	3/4"	1-1/4"
<b>25</b>	3/4"	1"	1-1/2"
<b>26</b>	1"	1-3/8"	2"

**5 Slide Travel (Ex. 2-1/4" = 2.25")**  
Slide Type - Travel Range

Body Style 'D'	
<b>23</b>	.25 inch to 14.00 inches
<b>24</b>	.25 inch to 18.00 inches
<b>25</b>	.25 inch to 18.00 inches
<b>26</b>	.25 inch to 20.00 inches
Body Style 'E'	
<b>23</b>	.25 inch to 18.00 inches
<b>24</b>	.25 inch to 20.00 inches
<b>25</b>	.25 inch to 20.00 inches
<b>26</b>	.25 inch to 20.00 inches

Available in .25" increments.  
CF for longer travel lengths.

**6 Tooling Plate Gap**

Additional distance between tooling plate and bearing block in 1" increments.

Example 2 = 2 inches  
(specify only if needed)

**7 Options**  
Cylinder Options

<b>Z1</b>	Nickel Plating (All Parts Except Rods and Fasteners <sup>1</sup> )
<b>Q</b>	Hardened Stainless Steel Guide Rods
<b>Q1</b>	Corrosion Resistant Coating- Guide Rods
<b>M</b>	Magnetic Piston <sup>2</sup>
<b>U7</b>	Ports and Cushions- Position 3
<b>V1</b>	Flourelastomer Seals
<b>DB</b>	Cushions- Both Ends <sup>2</sup>

**NOTES:**

- Requires "Q", "Q1" in addition.  
Piston Rod will be Stainless Steel.
- The selection of this option will affect the overall length of the slide.

**7 Options**  
Mount Options

<b>GX</b>	Side Mount- Position 4
<b>GV</b>	Side Mount- Position 2
<b>J2</b>	Dowel Pin in Tooling Plate- Normal Fit
<b>J6</b>	Dowel Pins in Body- Normal Fit

Switches (Includes Mtg Brkt.) (for use with 1-1/8" Bore)		Switches (Includes Mtg Brkt.) (for use with 1-1/4" Thru 2" Bore)	
Part#	Description	Part#	Description
KL690	Reed	KL690-4	Reed
KL691	PNP	KL691-4	PNP
KL692	NPN	KL692-4	NPN
KL693*	Reed QD	KL693*-4	Reed QD
KL694*	PNP QD	KL694*-4	PNP QD
KL695*	NPN QD	KL695*-4	NPN QD
A201A	<b>Cordset Only</b>	A201A	<b>Cordset Only</b>

\*Includes 5 meter cordset.

# Options- Z Series

**7 Options<sup>4,7</sup>**  
**Stop Collar Options**

Std*	Quiet*	
<b>AR</b>	<b>AT</b>	Stop Collar w/ Bumper Retract only.
<b>AE</b>	<b>AS</b>	Stop Collar w/ Bumper Extend only.
<b>GG</b>	<b>G22</b>	Stop Collar w/ Bumper- Ext with Prox. Provision for Both Extend and Retract.
<b>GH</b>	<b>G23</b>	Stop Collar w/ Bumper- Ret. with Prox. Provision for Retract only.
<b>GI</b>	<b>G24</b>	Stop Collar w/ Bumper- Both with Prox. Provision for Both Extend and Retract.

**NOTES:**

4. "Quiet" Bumper end of stroke location may vary due to compression of the bumper material.

\* The "Standard" Bumper is a 95a durometer urethane that significantly reduces noise.  
The "Quiet" Bumper is a 50a durometer soft urethane, which will compress to absorb end of stroke impact.

**7 Options<sup>5,6,7,8</sup>**  
**Shock and Sensing Options**

<b>GM</b>	Provision for Shock- Extend
<b>GN</b>	Provision for Shock- Retract
<b>GO</b>	Provision for Shock- Both
<b>G2</b>	Shock and 8mm Prox. Ready- Both
<b>G3</b>	Shock and 8mm Prox. Ready- Ext.
<b>G4</b>	Shock and 8mm Prox. Ready- Ret.
<b>G12</b>	Shock and 12mm Prox. Ready-Both
<b>G13</b>	Shock and 12mm Prox. Ready-Ext.
<b>G14</b>	Shock and 12mm Prox. Ready-Ret.

**NOTES:**

5. Shock absorbers and proximity switches must be ordered separately for options GM, GN, GO, G2, G3, G4, G12, G13, and G14.  
6. Options GM, GN and GO provide for the the mounting of shock absorbers. It includes guide rod mounted shock stop plates, a stop collar on the opposite guide rod, and slide body mounting holes for the shock absorbers brackets. (DOES NOT INCLUDE THE SHOCK ABSORBERS or MOUNTING BRACKETS).

**7 Options<sup>4,9</sup>**  
**Bumper Options**

Std*	Quiet*	
<b>BR</b>	<b>BJ</b>	Bumper Retract
<b>BS</b>	<b>BK</b>	Bumper Extend when combined with GM, GO, G2, G3, G12, G13 Options.
<b>BT</b>	<b>BL</b>	Bumper Retract when combined with GN, GO, G2, G4, G12, G14 Options.

**NOTES:**

7. Travel Adjustment Options, Bumper Options, Shock Options, and Sensing Options affect the overall length of the slide.  
8. G2, G3, G4, G12, G13, and G14 are Shock and Prox. Ready Options These include the mounting holes and shock bracket, guide rod mounted shock stop, stop collar mounted on the opposite guide rod, and mounted prox. bracket, and target. (DOES NOT INCLUDE THE SHOCK ABSORBER or PROX. SWITCH).  
9. Tooling plate extension is not available with bumper option (BR & BJ).

Stop & Travel Adjustments Kits*						
	Bumper	Guide Rod	Slide Size			
			23	24	25	26
Travel Adjustment -AR or -AE	Standard	Standard	KARS23	KARS24	KARS25	KARS26
		Oversize	KARO23	KARO24	KARO25	KARO26
Travel Adjustment -AT or -AS	Quiet	Standard	KATS23	KATS24	KATS25	KATS26
		Oversize	KATO23	KATO24	KATO25	KATO26
Prox & Trav adj -GG or -GH	Standard	Standard	KAGS23	KAGS24	KAGS25	KAGS26
		Oversize	KAGO23	KAGO24	KAGO25	KAGO26
Travel Adjustment -G22 or -G23	Quiet	Standard	KG2S23	KG2S24	KG2S25	KG2S26
		Oversize	KG2O23	KG2O24	KG2O25	KG2O26
Shock Absorber Stop -GM or -GN	N/A	Standard	KGMS23	KGMS24	KGMS25	KGMS26
		Oversize	KGMO23	KGMO24	KGMO25	KGMO26

\*For Models with "Z1" Option add "Z" to the end of the kit # ( Ex: KARS22 becomes KARS22Z).

# Dimensional Data- ZD Series

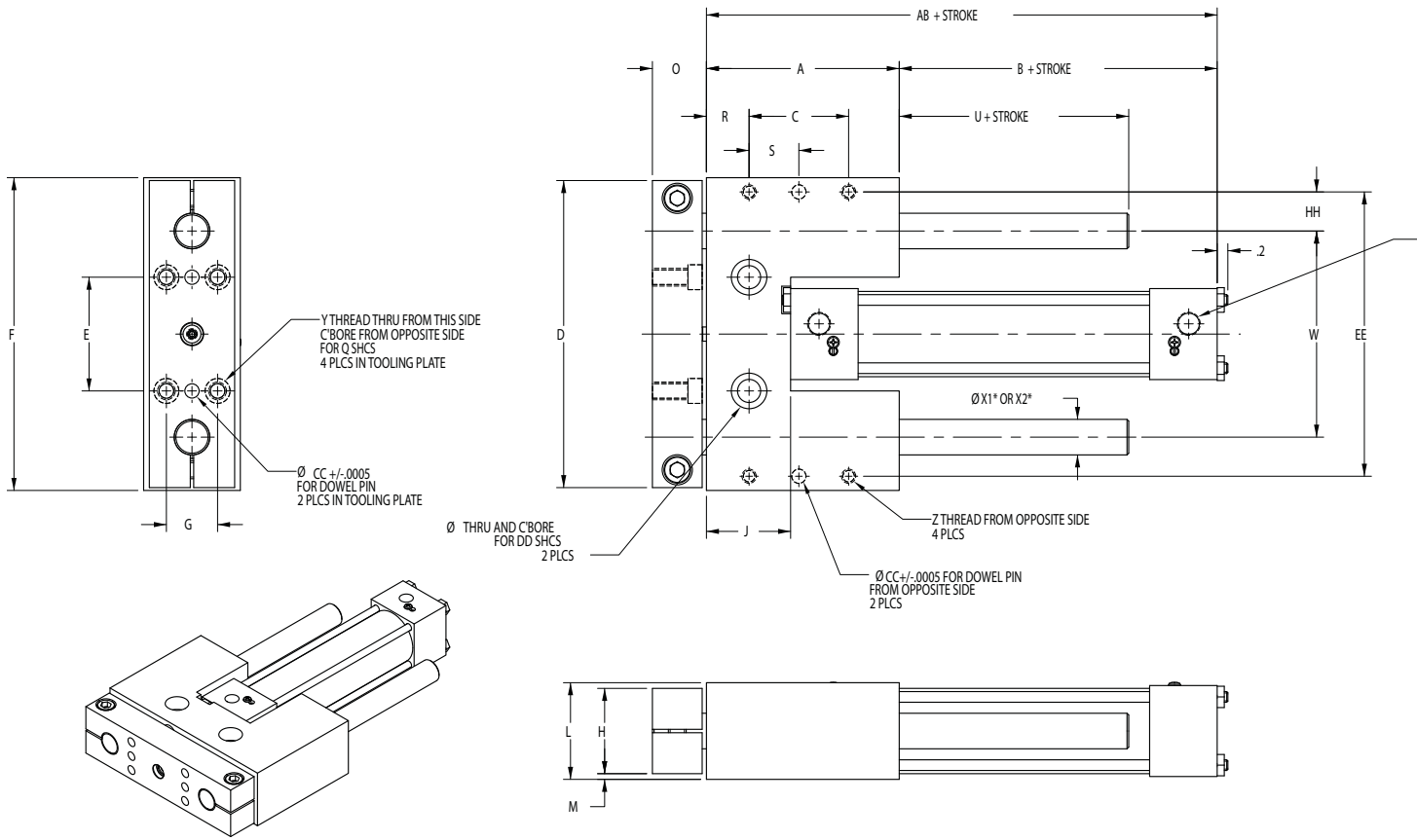

**Dimensional Specifications ZD Slide**

Bore	Size	A	B	C	D	E	F	G	H	J	L	M	O	Q	R
1-1/8	23	2.875	1.61	1.500	4.720	1.875	4.820	0.750	1.250	0.980	1.500	0.125	0.950	#10	0.625
1-1/4	24	3.390	1.59	1.750	5.400	2.000	5.500	0.900	1.500	1.480	1.700	0.100	0.950	1/4	0.750
1-1/2	25	3.650	1.48	1.750	6.450	2.375	6.550	1.300	2.000	1.500	2.200	0.100	1.200	5/16	0.875
2	26	5.000	.33	3.000	8.375	3.125	8.500	1.625	2.500	1.700	2.750	0.125	1.450	3/8	1.000

**Dimensional Specifications ZD Slide**

Bore	Size	S	U	V	W	X1	X2	Y	Z	AB	BB	CC	DD	EE	HH
1-1/8	23	0.750	0.000	1.125	3.250	0.500	0.625	1/4-20	1/4-20	4.48	1/8 NPT	1/4	5/16	4.330	0.540
1-1/4	24	0.875	0.035	1.312	3.625	0.625	0.750	5/16-18	1/4-20	4.98	1/8 NPT	1/4	3/8	5.000	0.688
1-1/2	25	0.875	0.025	1.562	4.250	0.750	1.000	3/8-16	3/8-16	5.13	3/8 NPT	3/8	3/8	5.875	0.813
2	26	1.500	0.175	2.062	5.750	1.000	1.375	1/2-13	3/8-16	5.33	1/4 NPT	3/8	1/2	7.750	1.000

# Dimensional Data- ZE Series

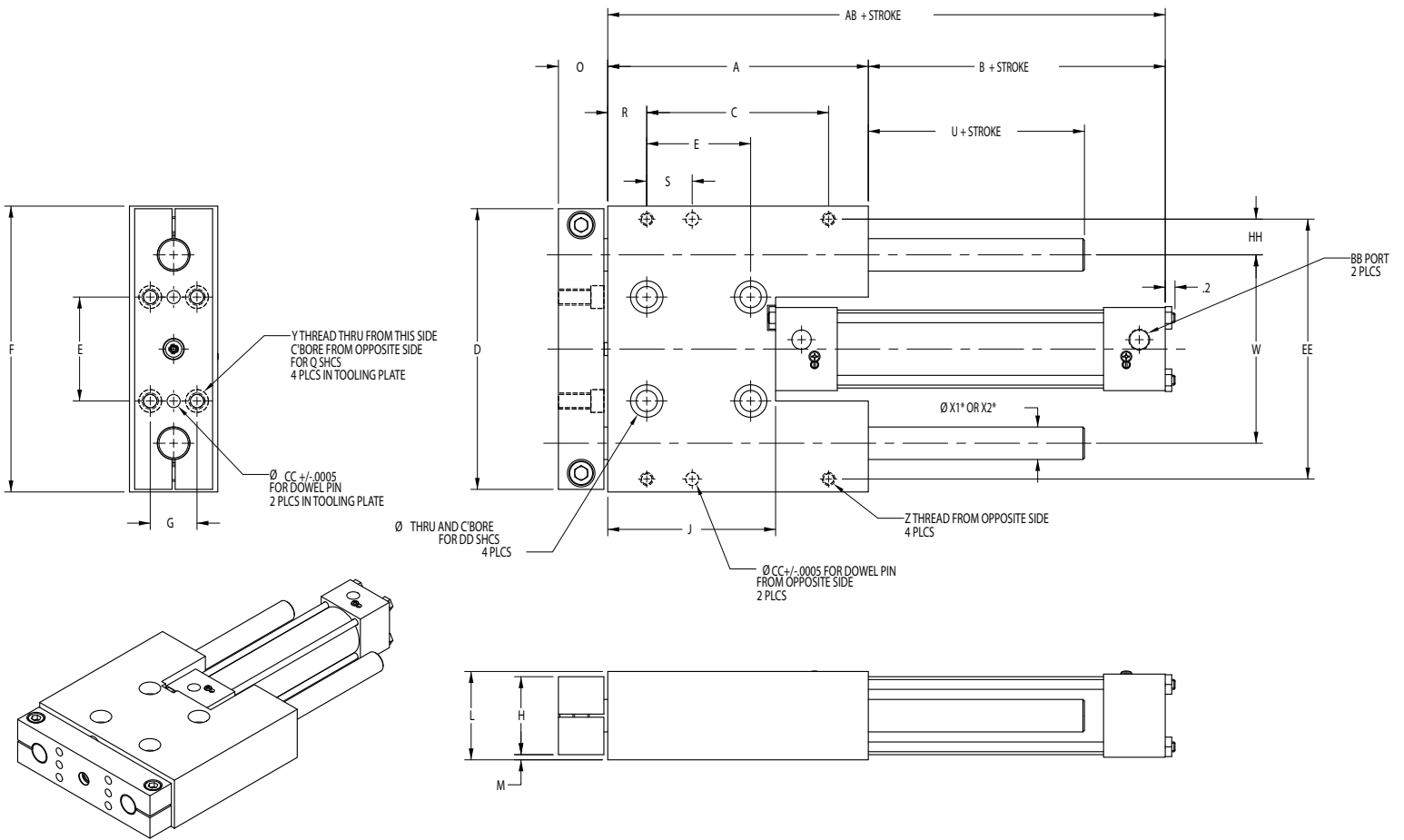

**Dimensional Specifications ZE Slide**

Bore	Size	A	B	C	D	E	F	G	H	J	L	M	O	Q	R
1-1/8	23	4.765	1.72	3.500	4.720	1.875	4.820	0.750	1.250	2.980	1.500	0.125	0.950	#10	0.625
1-1/4	24	5.015	1.72	3.500	5.400	2.000	5.500	0.900	1.500	3.230	1.700	0.100	0.950	1/4	0.750
1-1/2	25	5.765	1.61	4.000	6.450	2.375	6.550	1.300	2.000	3.750	2.200	0.100	1.200	5/16	0.875
2	26	8.000	.33	6.000	8.375	3.125	8.500	1.625	2.500	4.700	2.750	0.125	1.450	3/8	1.000

**Dimensional Specifications ZE Slide**

Bore	Size	S	U	V	W	X1	X2	Y	Z	AB	BB	CC	DD	EE	HH
1-1/8	23	0.750	0.160	1.125	3.250	0.500	0.625	1/4-20	1/4-20	6.48	1/8 NPT	1/4	5/16	4.330	0.540
1-1/4	24	0.875	0.160	1.312	3.625	0.625	0.750	5/16-18	1/4-20	6.43	1/8 NPT	1/4	3/8	5.000	0.688
1-1/2	25	0.875	0.160	1.562	4.250	0.750	1.000	3/8-16	3/8-16	7.38	1/8 NPT	3/8	3/8	5.875	0.813
2	26	1.500	0.175	2.062	5.750	1.000	1.375	1/2-13	3/8-16	8.33	1/4 NPT	3/8	1/2	7.750	1.000

# Engineering Data- ZD & ZE Series

## Maximum Rolling Load & Deflection Graphs

### ZDB23 with 1/2" Shafts and Linear Ball Bushings

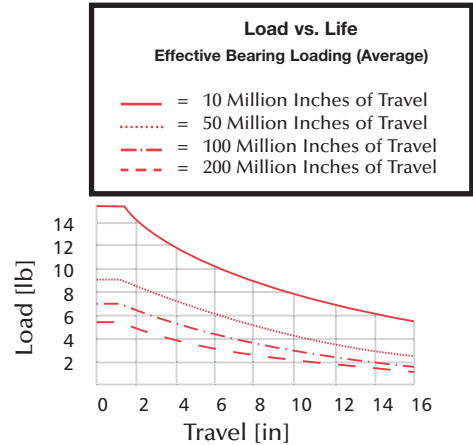
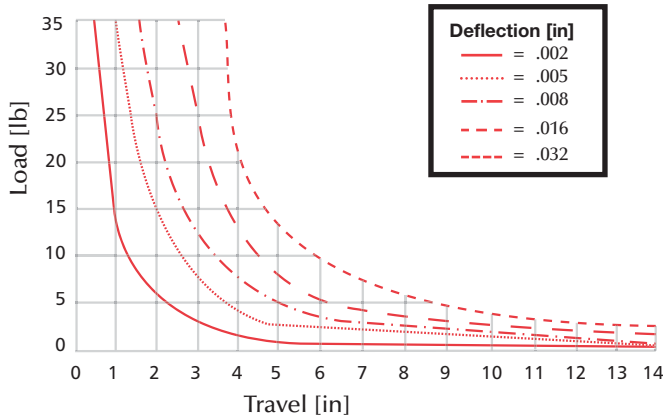

### ZDC23 with 1/2" Shafts and Composite Bushings

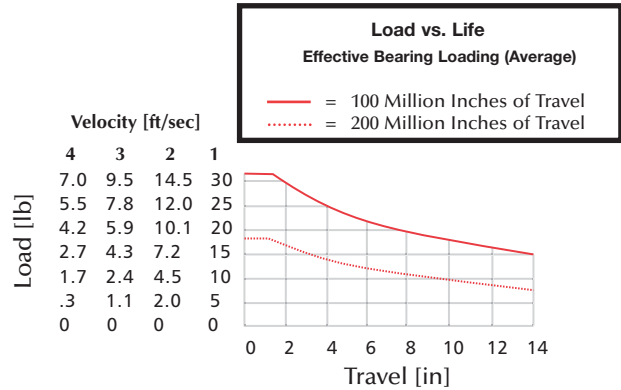
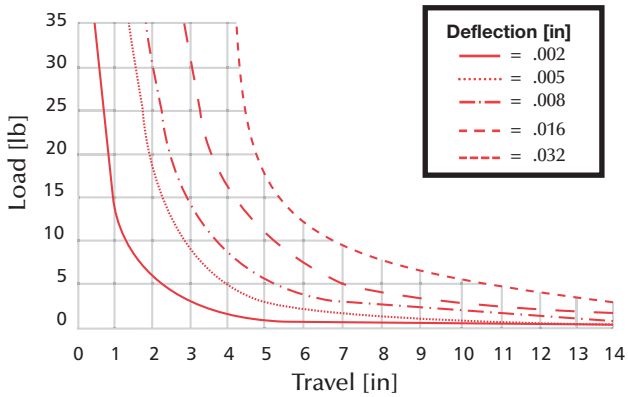

### ZDD23 with 5/8" Shafts and Composite Bushings

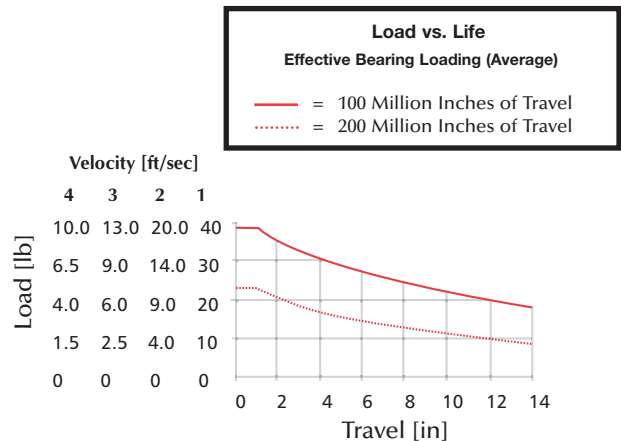
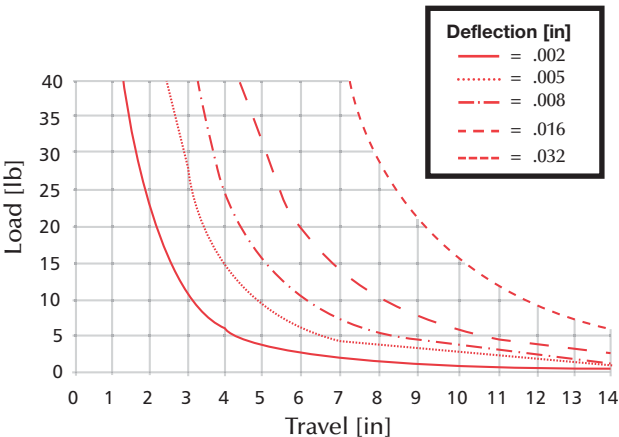

# Engineering Data- ZD & ZE Series

## Maximum Rolling Load & Deflection Graphs

### ZEB23 with 1/2" Shafts and Linear Ball Bushings

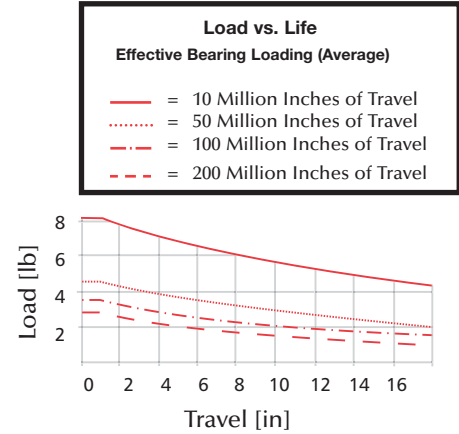
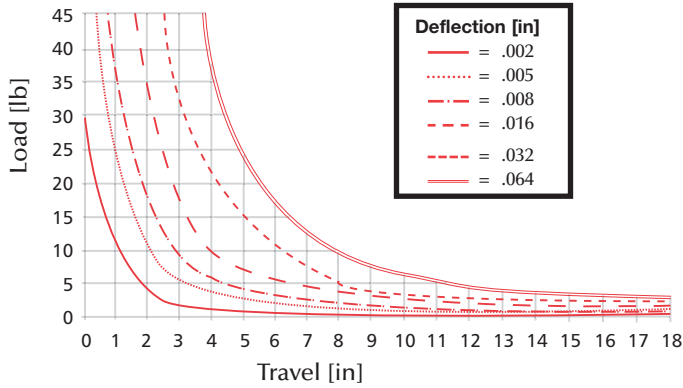

### ZEC23 with 1/2" Shafts and Composite Bushings

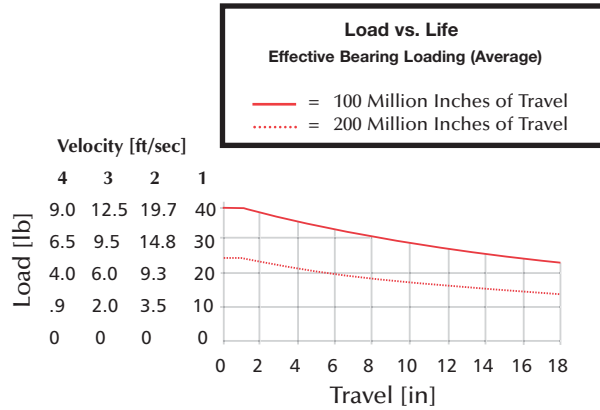
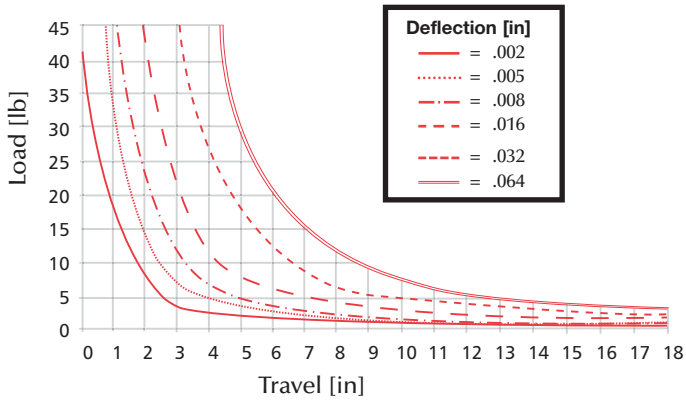

### ZED23 with 5/8" Shafts and Composite Bushings

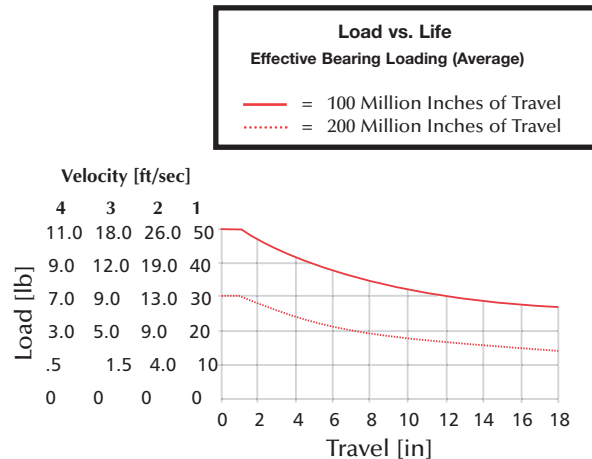
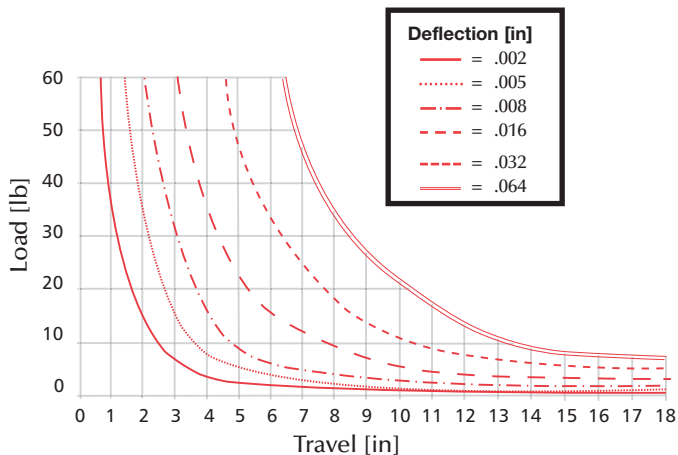

# Engineering Data– ZD & ZE Series

## Maximum Rolling Load & Deflection Graphs

### ZDB24 with 5/8" Shafts and Linear Ball Bushings

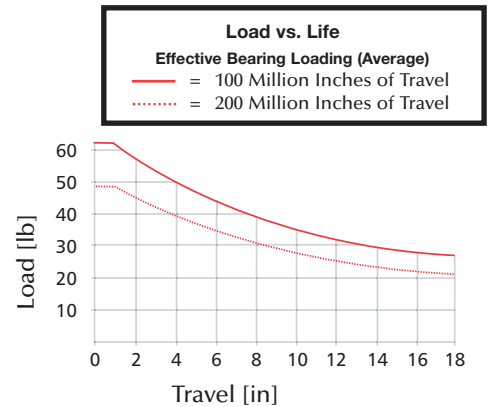
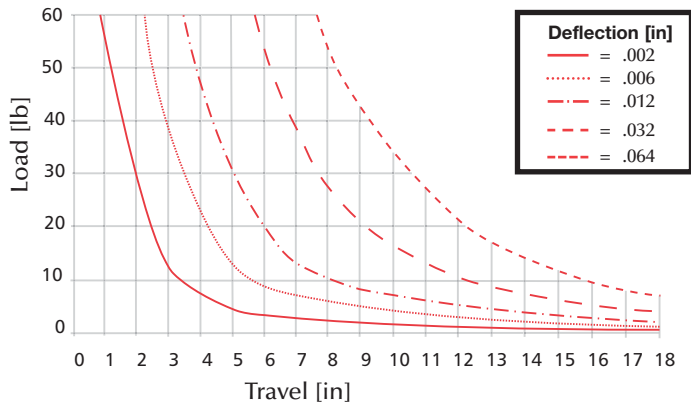

### ZDC24 with 5/8" Shafts and Composite Bushings

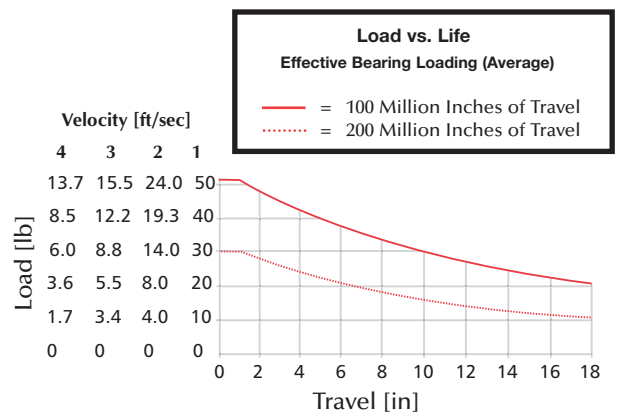
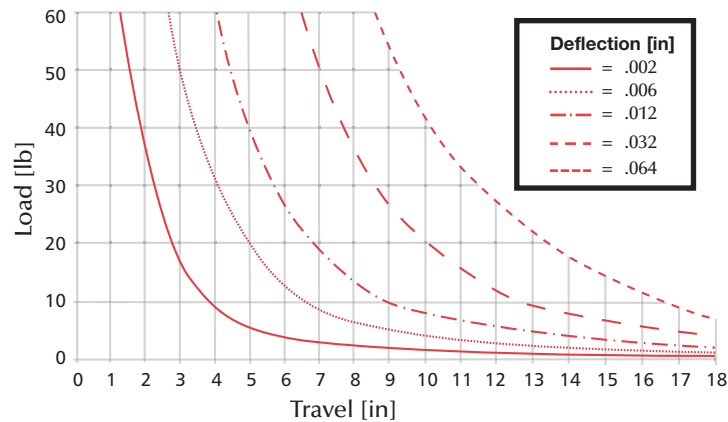

### ZDD24 with 3/4" Shafts and Composite Bushings

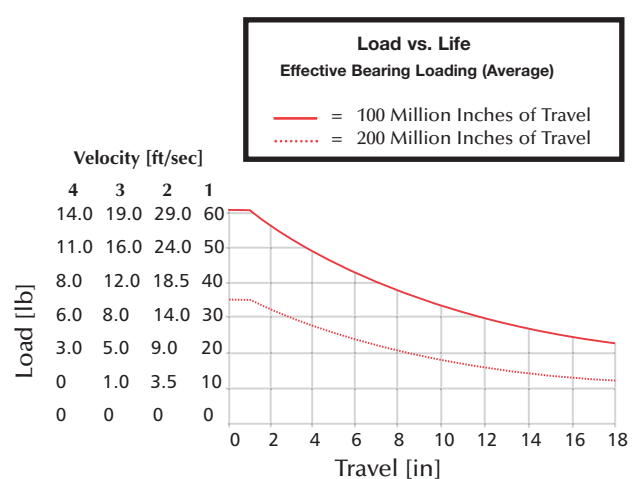
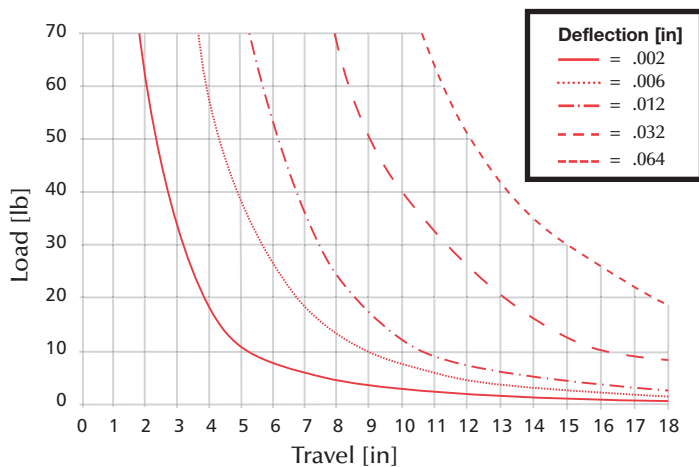

# Engineering Data- ZD & ZE Series

## Maximum Rolling Load & Deflection Graphs

### ZEB24 with 5/8" Shafts and Linear Ball Bushings

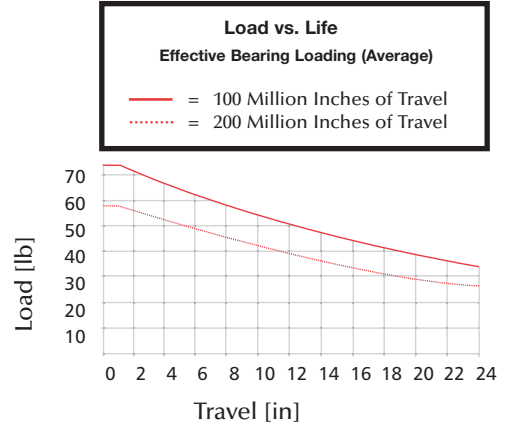
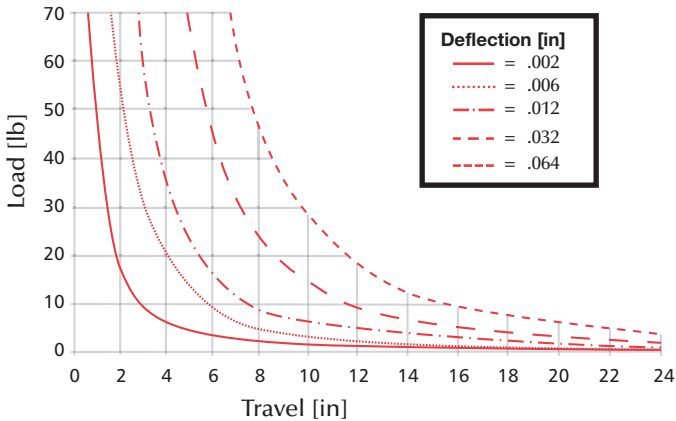

### ZEC24 with 5/8" Shafts and Composite Bushings

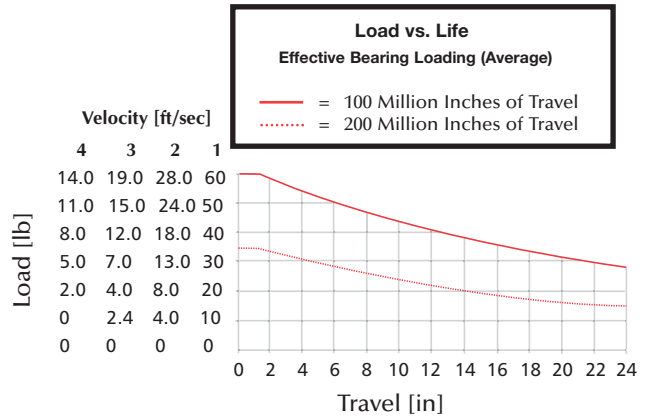
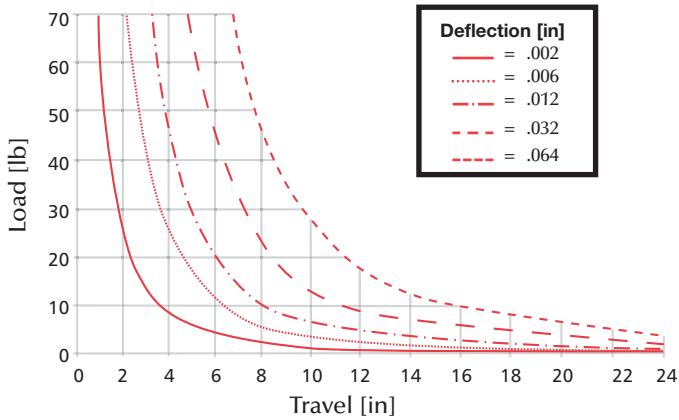

### ZED24 with 3/4" Shafts and Composite Bushings

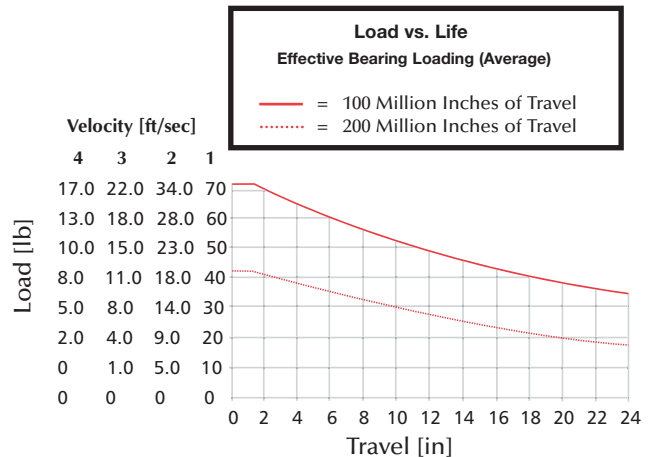
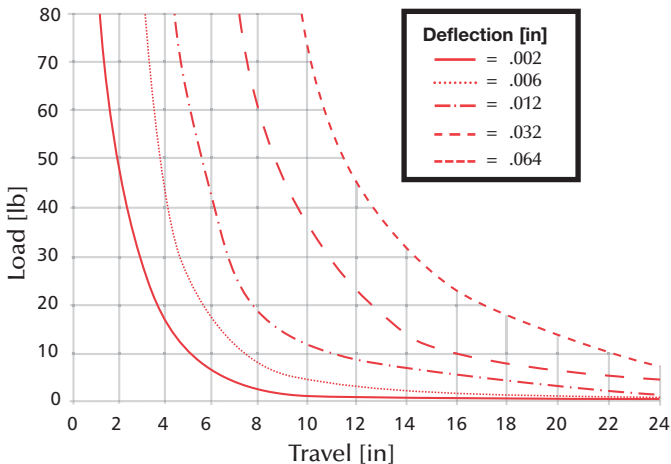

# Engineering Data- ZD & ZE Series

## Maximum Rolling Load & Deflection Graphs

### ZDB25 with 3/4" Shafts and Linear Ball Bushings

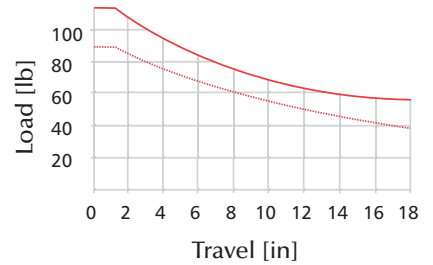
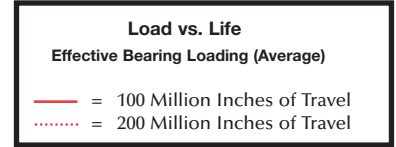
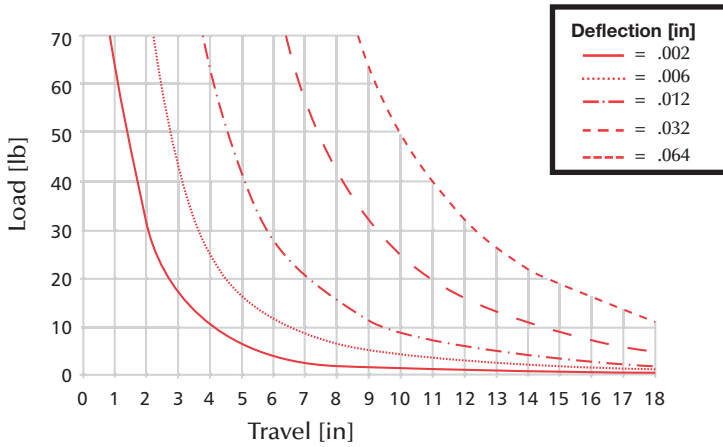

### ZDC25 with 3/4" Shafts and Composite Bushings

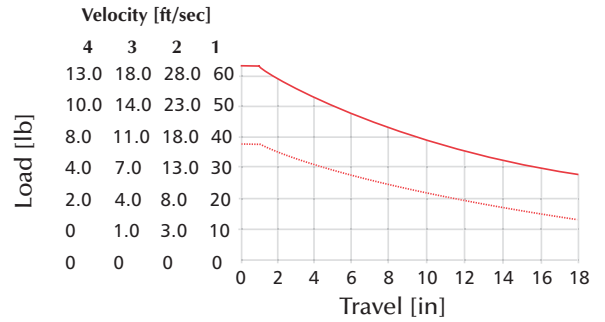
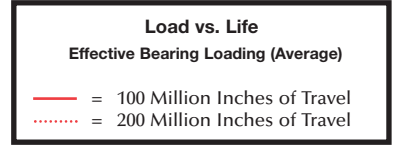
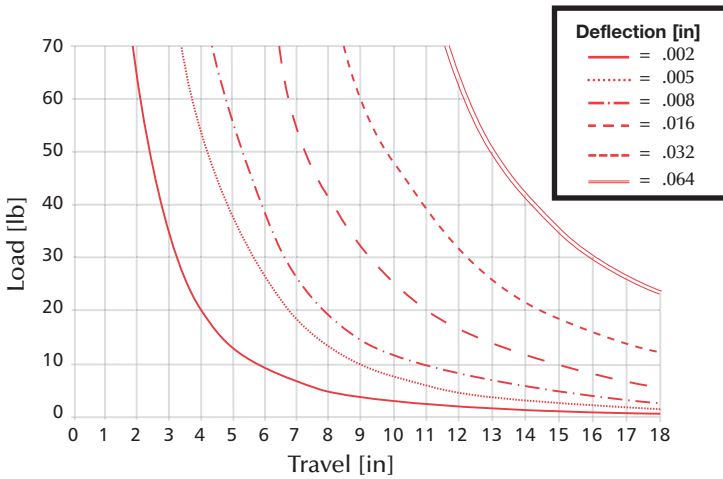

### ZDD25 with 1" Shafts and Composite Bushings

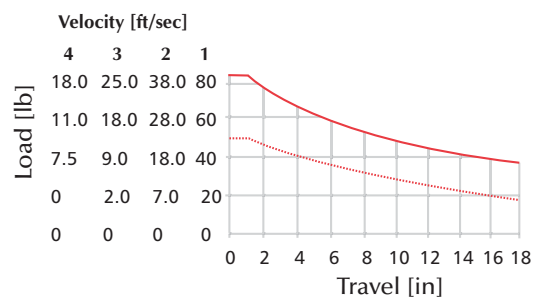
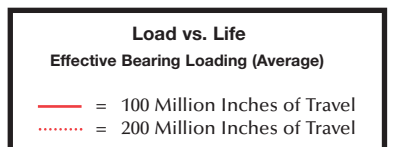
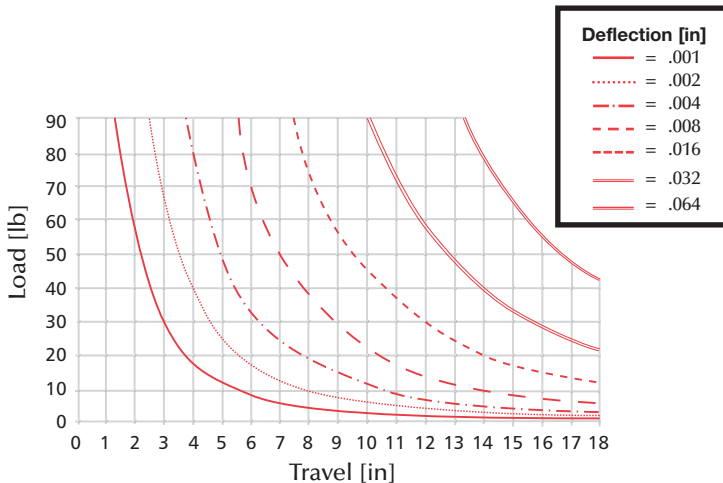

# Engineering Data- ZD & ZE Series

## Maximum Rolling Load & Deflection Graphs

### ZEB25 with 3/4" Shafts and Linear Ball Bushings

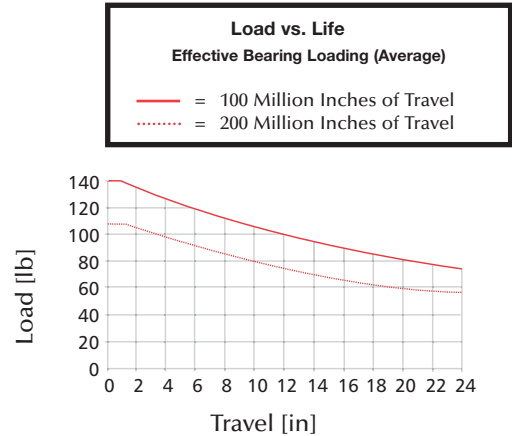
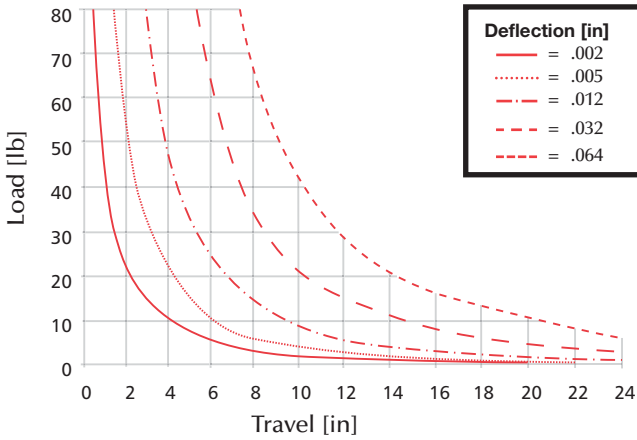

### ZEC25 with 3/4" Shafts and Composite Bushings

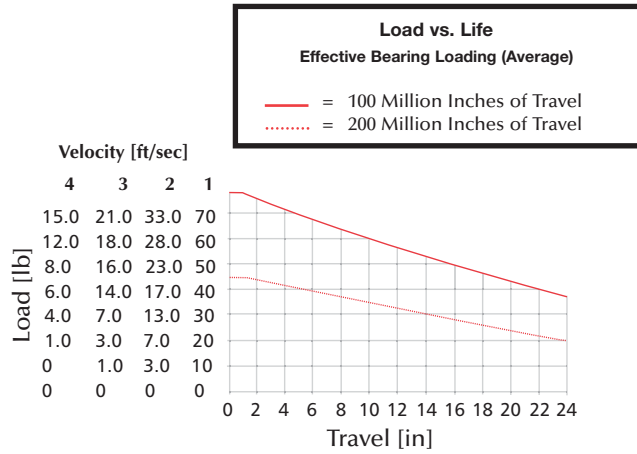
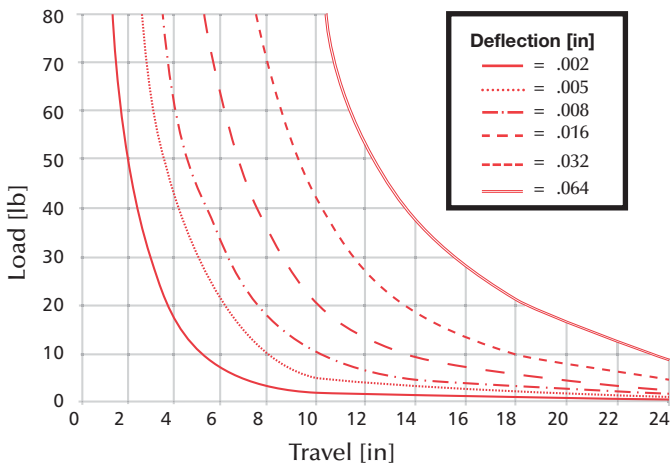

### ZED25 with 1" Shafts and Composite Bushings

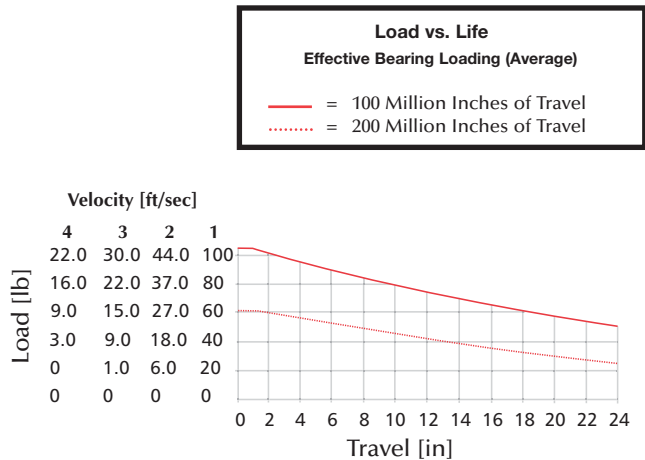
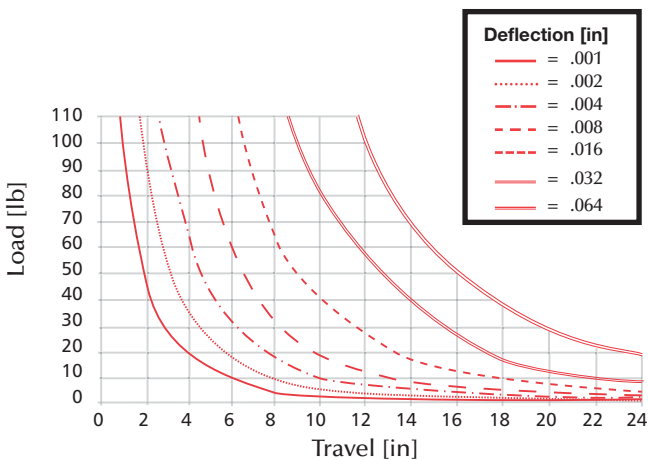

# Engineering Data- ZD & ZE Series

## Maximum Rolling Load & Deflection Graphs

### ZDB26 with 1" Shafts and Linear Ball Bushings

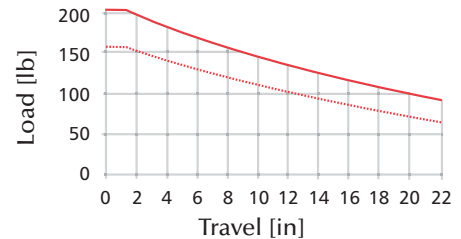
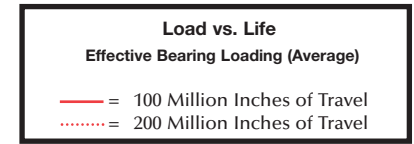
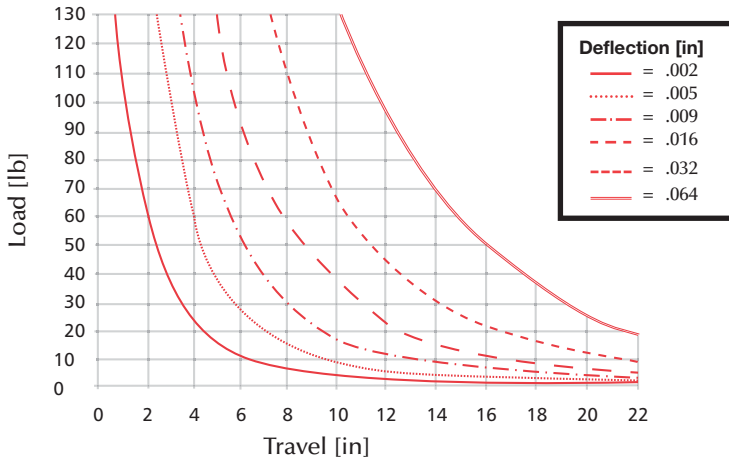

### ZDC26 with 1" Shafts and Composite Bushings

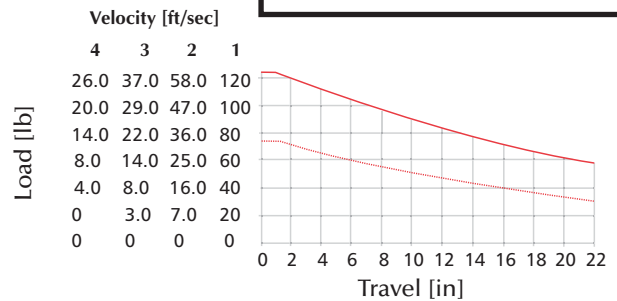
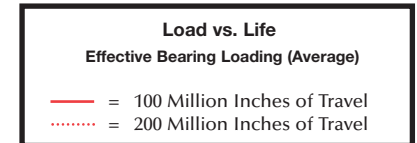
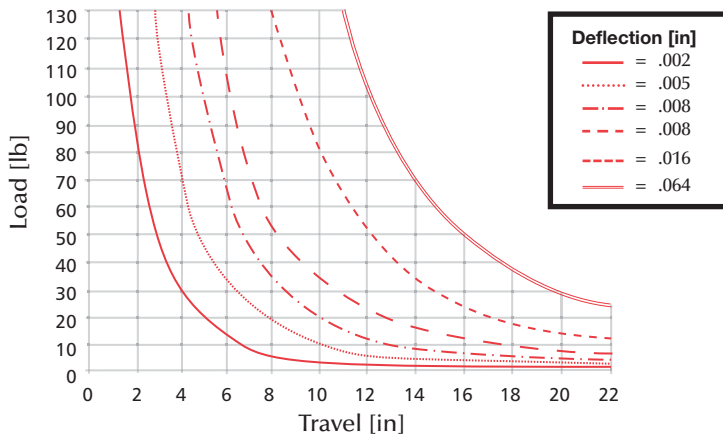

### ZDD26 with 1 3/8" Shafts and Composite Bushings

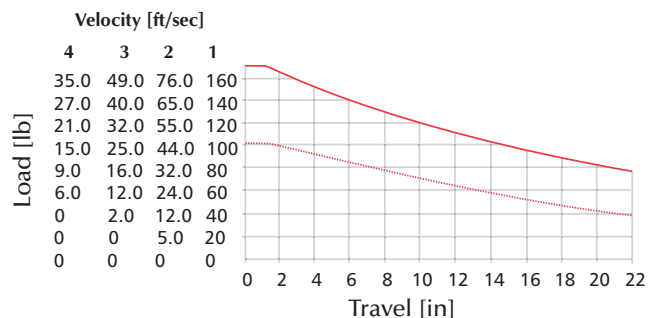
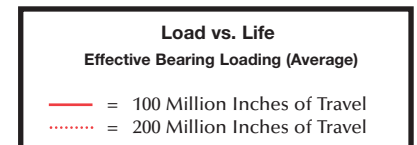
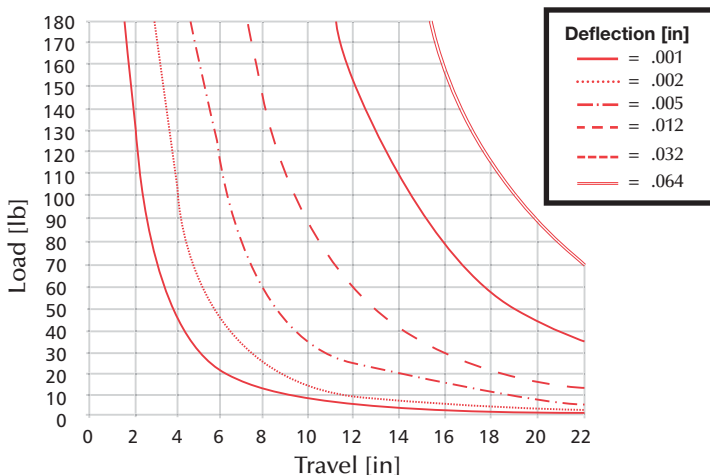

# Engineering Data- ZD & ZE Series

## Maximum Rolling Load & Deflection Graphs

### ZEB26 with 1" Shafts and Linear Ball Bushings

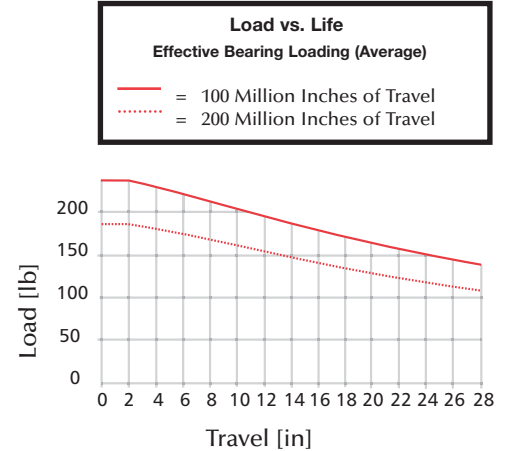
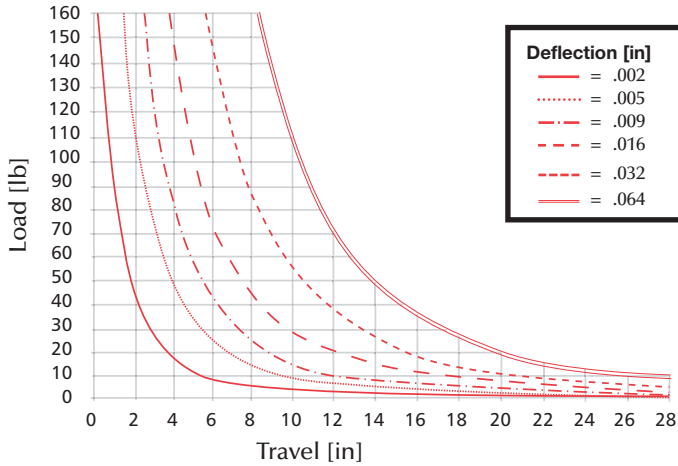

### ZEC26 with 1" Shafts and Composite Bushings

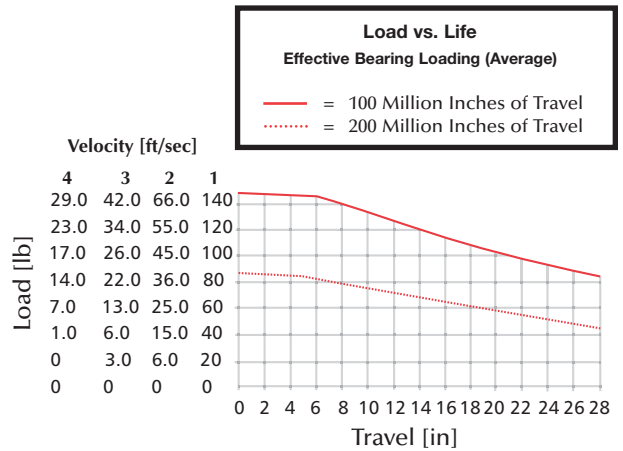
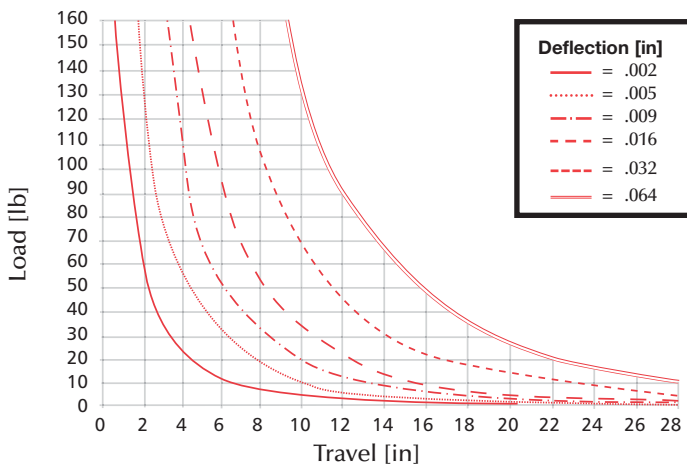

### ZED26 with 1-3/8" Shafts and Composite Bushings

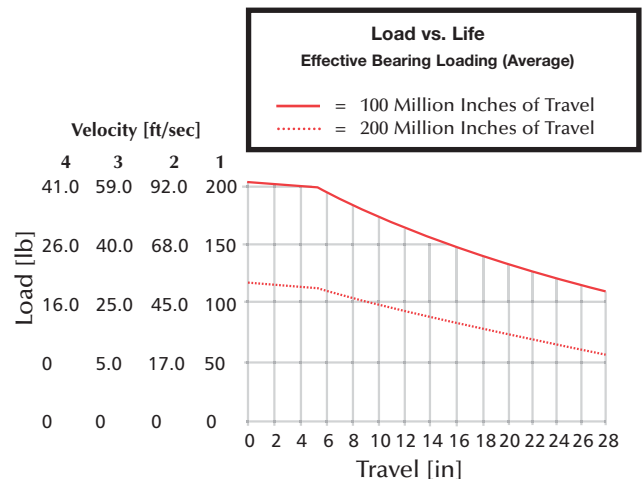
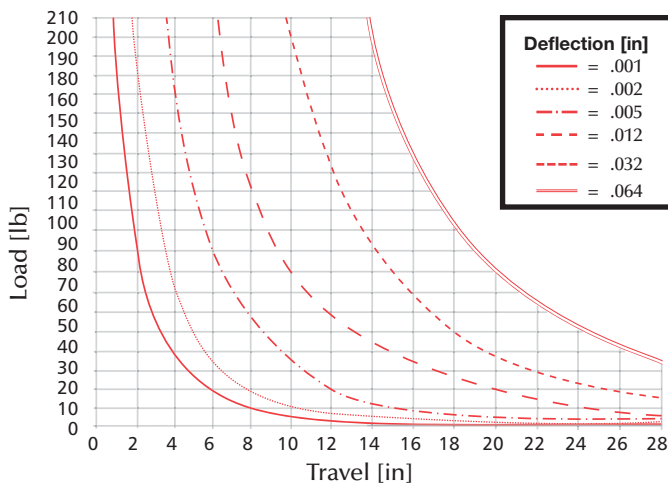

## Special Conditions and Limited Warranty

Determination of the suitability of any information or product for the application contemplated by any user or the manner of that use is the sole responsibility of the user.

Turn-Act Products, reserves the right to improve or change designs without notice.

All orders are subject to acceptance by the factory sales department.

Turn-Act Products agrees to repair or replace to the original purchaser any standard parts or products for a period of 12 months from date of shipment which Turn-Act Products determines upon inspection to be defective in workmanship or material. Wear components including but not limited to seals and bearings are excluded from this warranty.

Under no circumstance may merchandise be returned without written authorization from the factory.

This warranty is void in the event the product has been tampered with, altered, or serviced by unauthorized personnel.

Turn-Act Products total responsibility for any claims, damages, losses or liabilities related to the product covered thereunder shall not exceed the purchase price of such product. In no event shall Turn-Act Products be liable for any special, indirect, incidental or consequential damages of any character, including but not limited to loss of use of productive facilities or equipment, lost profit, property damage, transportation, installation or removal or lost production whether suffered by purchaser or third party. Turn-Act Products disclaims all liability for any and all cost, claims demands, charges, expenses, and other damages, either direct or indirect, incident to all property damage arising out of any cause of action based on strict liability. This warranty gives you specific legal rights and you may have other rights, which vary from state to state.

**Turn-Act**  
105 Commerce Way  
Westminster, SC 29693  
p. 864 647 9521  
f. 864 647 9574  
[www.itt.com](http://www.itt.com)  
[www.turn-act.com](http://www.turn-act.com)

